

Fig : BV-402

Main Parameter Specification

- ◆ Design and Manufacture : JIS B2031
- ◆ Face to Face : JIS B2002
DN15-100(6)
DN125-200(39)
- ◆ End Flange Dimensions : JIS B2212
- ◆ Nominal Pressure : 10K
- ◆ Pressure test : JIS B2003



Main parts and materials

NO.	Part Name	Material
1	Body	Cast iron (FC200 or FCD400)
2	Bonnet	Cast iron (FC200 or FCD400)
3	Nut	Carbon steel
4	Bolting	Carbon steel
5	Ball	Stainless steel (SUS304)
6	Seat	PTFE
7	Gasket	PTFE
8	Stem	Stainless steel (SUS304)
9	Stem Packing	PTFE
10	Gland flange	Cast iron (FC200 or FCD400)
11	Stop collar	Carbon steel
12	Circlip	Carbon steel
13	Lever	Ductile iron (FCD400)
14	Gland bolt	Carbon steel

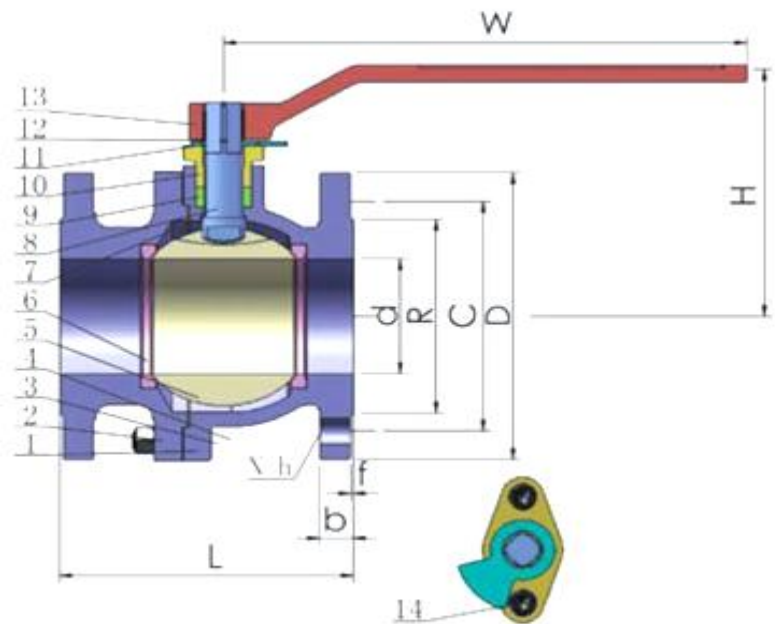

Unit: mm

Main Dimensions

DN	d	L	D	C	R	b	N-h	f	H	W
15	15	108	95	70	52	14	4-Ø15	1	78	130
20	20	117	100	75	58	16	4-Ø15	1	113	160
25	25	127	125	90	70	16	4-Ø19	1	107	160
32	32	140	135	100	80	18	4-Ø19	2	113	160
40	40	165	140	105	85	18	4-Ø19	2	130	250
50	50	178	155	120	100	20	4-Ø19	2	146	250
65	65	190	175	140	120	22	4-Ø19	2	176	350
80	80	203	185	150	130	22	8-Ø19	2	222	350
100	100	229	210	175	155	24	8-Ø19	2	222	400
125	125	356	250	210	185	24	8-Ø23	2	250	600
150	150	394	280	240	215	26	8-Ø23	2	275	600
200	200	457	330	290	265	26	12-Ø23	2	-	-
250	250	533	400	355	325	30	12-Ø25	2	-	-

* Design and materials are subject to change without notice.

