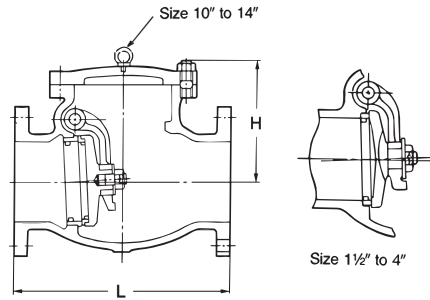

Fig. 10FCO(Bronze trim)
Fig. 10FCOS (13 Cr. trim)



Class JIS 10K

Bolted cover, swing type disc.



120°C Non-shock water 1.37 MPa (14 kgf/cm²)
 120°C Water, oil, air 0.98 MPa (10 kgf/cm²)
 120°C Gas 0.69 MPa (7 kgf/cm²)
 Saturated steam..... 0.69 MPa (7 kgf/cm²)
 Hydrostatic shell test2.06 MPa (21 kgf/cm²)
 Size 10" to 14" for 1.86 MPa (19kgf/cm²)
 Hydrostatic seat test1.51-0.50 MPa (15.4-5.1kgf/cm²)
 Size 10" to 14" for 1.08-0.35 MPa (11-3.6kgf/cm²)
 Pneumatic seat test0.59 MPa (6 kgf/cm²)

Materials

Parts	JIS materials	
	10FCO	10FCOS
Body	FC200	
Cover	FC200	
Disc	Size 1 1/2" to 4"	BC6 SUS403
	Size 5" to 14"	FC200
Seat ring	Size 2" to 4"	BC6 SCS1
	Size 1 1/2", 5 to 14"	SUS403
Disc nut	SS400	
Hinge pin	C3771BD	SUS403
Plug	SS400	
Gasket	Asbestos-free	
Cover bolt/nut	SS400	
Arm	BC6	SCS13A
Eye bolt (Size 10" to 14")	SS400	

Dimensions

Valve size	mm	40	50	65	80	100	125	150	200	250	300	350
	inch	1 1/2	2	2 1/2	3	4	5	6	8	10	12	14
L Face-to face		190	200	220	240	290	360	410	500	620	700	787
H Height (OPEN)		106	111	121	145	165	207	225	268	315	356	381

Fig. 125FCO(Bronze trim)
Fig. 125FCOS (13 Cr. trim)



Class 125

200 psi. Water, oil, Gas 65°C
 125 psi. Saturated steam
 350 psi. Hydrostatic shell test
 220 psi. Hydrostatic seat test
 80 psi. Pneumatic seat test

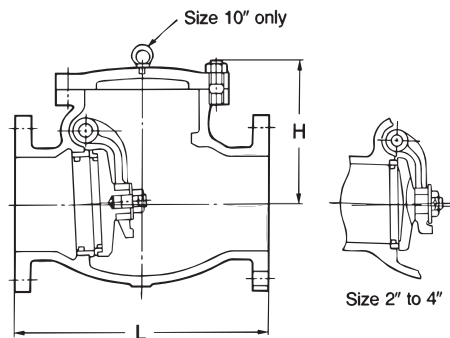

Bolted cover, swing type disc.

Materials

Parts	JIS materials	
	125FCO	125FCOS
Body	A126 Class B	
Cover	A126 Class B	
Disc	Size 2" to 4"	B62 F6a
	Size 5" to 10"	A126 Class B
Disc nut	Carbon steel	
Seat ring	Size 2" to 4"	B62 CA-15
	Size 5" to 10"	F60
Hinge pin	No.C37700	Type 403
Arm	B62	CF8
Gasket	Asbestos-free	
Cover bolt/nut	Carbon steel	
Eye bolt (Size 10" only)	Carbon steel	
Flanged ends	ASME B16.1	
F-F dimension	ASME B16.10	
Wall thickness	KITZ Std.	

Dimensions

Valve size	mm	50	65	80	100	125	150	200	250
	inch	2	2 1/2	3	4	5	6	8	10
L Face-to face		203	216	241	292	330	356	495	622
H Height		111	121	145	165	207	225	268	315

e.g

Fig. 10FW (Bronze trim)



Class JIS 10K

80°C Non-shock water....1.37MPa (14kgf-cm²)
 80°C water, oil, air.....0.98MPa (10kgf-cm²)
 Hydrostatic shell test.....2.06MPa (21kgf/cm²)
 Hydrostatic seat test.....15.1-0.05Pma (15.4-0.5kgf/cm²)

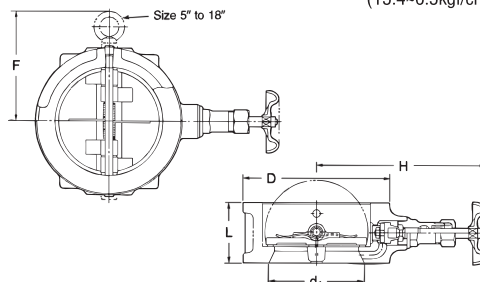

Materials

Parts	JIS materials	
Body	FC200+NBR	
Disc	BC6	
Disc washer	SS400	
Body washer	Size 2" to 12"	Reinforced PTFE
	Size 14" to 18"	C3771BD
Plug	SWCH10R	
Spring	SUS304	
Eye bolt (Size 5" to 18")	S25C	

Bypass valve

Bonnet	FCMB340
Stem	SUS403
Disc	Reinforced PTFE
Disc washer (Size 6" to 18")	SS400
Disc holder	SUS403
Body seat ring	SUS403
Gasket	C1100P
Gland packing	Asbestos-free
Handwheel	FCMB270

Flanged ends	JIS 10K water
F-F dimension	KITZ Std.
Wall thickness	JIS B2031

Dimensions

Valve size	mm	50	65	80	100	125	150	200	250	300	350	400	450
	inch	2	2 1/2	3	4	5	6	8	10	12	14	16	18
L		54	54	57	64	70	76	95	108	144	184	191	203
H Height (OPEN)		160	166	172	185	198	240	266	292	317	337	365	391
F		-	-	-	-	135	150	177	216	240	284	314	352
D		101	121	131	156	187	217	267	330	375	420	483	538
d ₁		51	64	77	102	127	153	204	254	305	356	407	458
d ₂		65	77	90	115	141	167	218	270	321	359	410	460
R		31	37	43	55	66	78	104	129	155	176	201	225